

用途:用于闪光灯闪光驱动,中功率放大。

Purpose: Strobe flash, medium power amplifier applications.

特点: 直流电流增益高, 放大线性好, 饱和压降低。

Features: High DC current gain and excellent hFE linearity, low saturation voltage.

极限参数/Absolute maximum ratings(Ta=25°C)

参数符号 Symbol	数值 Rating	单位 Unit
V <sub>CB0</sub>	-20	V
V <sub>CE0</sub>	-10	V
V <sub>EB0</sub>	-6.0	V
I <sub>C</sub>	-2.0	A
I <sub>CP</sub>	-4.0	A
I <sub>B</sub>	-2.0	A
P <sub>C</sub>	900	mW
T <sub>j</sub>	150	°C
T <sub>stg</sub>	-55~150	°C

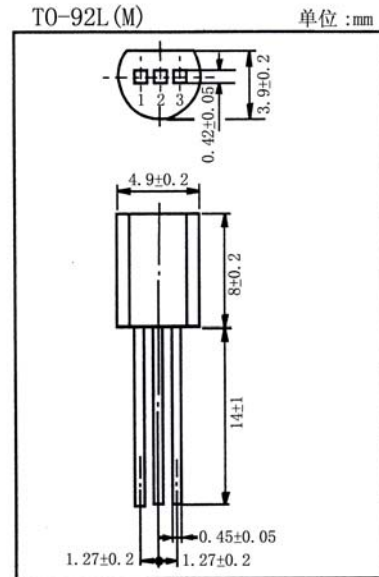

引脚: 1. E 2. C 3. B

电性能参数/Electrical characteristics(Ta=25°C)

参数符号 Symbol	测试条件 Test condition	数值 Rating			单位 Unit
		最小值 Min	典型值 Typ	最大值 Max	
V <sub>CE0</sub>	I <sub>C</sub> =-10mA I <sub>B</sub> =0	-10			V
V <sub>EB0</sub>	I <sub>E</sub> =-1.0mA I <sub>C</sub> =0	-6.0			V
I <sub>CB0</sub>	V <sub>CB</sub> =-20V I <sub>E</sub> =0			-0.1	μA
I <sub>EB0</sub>	V <sub>EB</sub> =-6.0V I <sub>C</sub> =0			-0.1	μA
h <sub>FE(1)</sub>	V <sub>CE</sub> =-1.0V I <sub>C</sub> =-0.5A	140		600	
h <sub>FE(2)</sub>	V <sub>CE</sub> =-1.0V I <sub>C</sub> =-4.0A	60	120		
V <sub>CE(sat)</sub>	I <sub>C</sub> =-2.0A I <sub>B</sub> =-50mA		-0.20	-0.50	V
V <sub>BE</sub>	V <sub>CE</sub> =-1.0V I <sub>C</sub> =-2.0A		-0.83	-1.5	V
f <sub>T</sub>	V <sub>CE</sub> =-1.0V I <sub>C</sub> =-0.5A		140		MHz
C <sub>ob</sub>	V <sub>CB</sub> =-10V I <sub>E</sub> =0 f=1.0MHz		50		pF

h<sub>FE(1)</sub>分档/h<sub>FE(1)</sub> Classifications: A:140~280 B:200~400 C:300~600



# 2SA1160 (3CG1160)

