

Hi-Rel 60 V, 0.6 A PNP transistor

Datasheet - production data

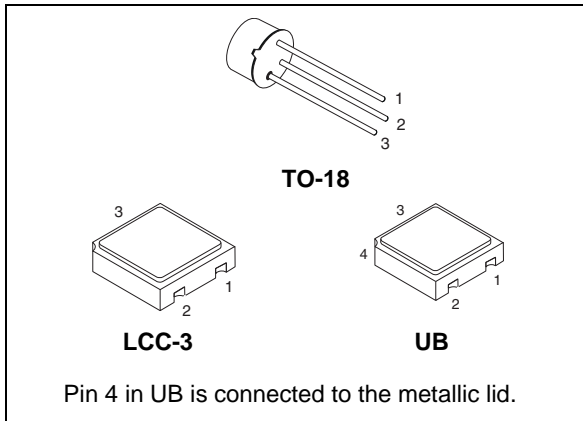
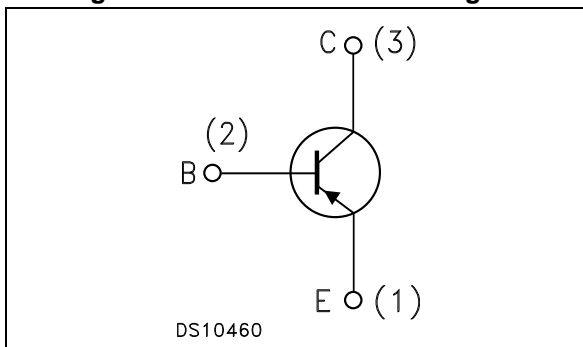

Figure 1. Internal schematic diagram



Features

Parameter	Value
BV_{CEO}	60 V
I_C (max)	0.6 A
H_{FE} at 10 V - 150 mA	> 100

- Hermetic packages
- ESCC and JANS qualified
- European preferred part list EPPL

Description

The 2N2907AHR is a silicon planar PNP transistor specifically designed and housed in hermetic packages for aerospace and Hi-Rel applications. It is available in the JAN qualification system (MIL-PRF19500 compliance) and in the ESCC qualification system (ESCC 5000 compliance). In case of discrepancies between this datasheet and the relevant agency specification, the latter takes precedence.

Table 1. Device summary

Device	Qualification system	Agency specification	Package	Radiation level	EPPL
JANSR2N2907AUBx	JANSR	MIL-PRF-19500/291	UB	100 krad - high and low dose rate	-
JANS2N2907AUBx	JANS	MIL-PRF-19500/291	UB	-	-
2N2907ARUBx	ESCC Flight	5202/001	UB	100 krad - low dose rate	Target
2N2907AUBx	ESCC Flight	5202/001	UB	-	Target
SOC2907ARHRx	ESCC Flight	5202/001	LCC-3	100 krad - low dose rate	Yes
SOC2907AHRx	ESCC Flight	5202/001	LCC-3	-	Yes
2N2907ARHRx	ESCC Flight	5202/001	TO-18	100 krad - low dose rate	-
2N2907AHRx	ESCC Flight	5202/001	TO-18	-	-

Contents

1	Electrical ratings	3
2	Electrical characteristics	4
2.1	JANS electrical characteristics	4
2.2	ESCC electrical characteristics	5
2.3	Electrical characteristics (curves)	6
2.4	Test circuits	7
3	Radiation hardness assurance	9
4	Package mechanical data	13
5	Order codes	17
6	Shipping details	19
6.1	Date code	19
6.2	Documentation	19
7	Revision history	20

1 Electrical ratings

Table 2. Absolute maximum ratings

Symbol	Parameter	Value	Unit
V_{CBO}	Collector-base voltage ($I_E = 0$)	-60	V
V_{CEO}	Collector-emitter voltage ($I_B = 0$)	-60	V
V_{EBO}	Emitter-base voltage ($I_C = 0$)	-5	V
I_C	Collector current for TO-18	-0.6	A
	for LCC-3 and UB	-0.5	A
P_{TOT}	Total dissipation at $T_{amb} \leq 25\text{ °C}$ ESCC: TO-18	0.4	W
	LCC-3 and UB	0.4	
	LCC-3 and UB ⁽¹⁾	0.73	
	JANS: UB	0.5	
	Total dissipation at $T_{case} \leq 25\text{ °C}$ ESCC: TO-18	1.8	
T_{stg}	Total dissipation at $T_{sp(IS)} = 25\text{ °C}$ JANS: UB	1	
	Storage temperature	-65 to 200	°C
T_J	Max. operating junction temperature	200	°C

1. When mounted on a 15 x 15 x 0.6 mm ceramic substrate.

Table 3. Thermal data

Symbol	Parameter	LCC-3 UB	TO-18	Unit
R_{thJC}	Thermal resistance junction-case (max) for JANS	-	-	°C/W
	Thermal resistance junction-case (max) for ESCC	-	97	
$R_{thJSP(IS)}$	Thermal resistance junction-solder pad (infinite sink) (max) for JANS	90	-	
	Thermal resistance junction-solder pad (infinite sink) (max) for ESCC	-	-	
R_{thJA}	Thermal resistance junction-ambient (max) for JANS	325	-	
	Thermal resistance junction-ambient (max) for ESCC	437 240 ⁽¹⁾	437	

1. When mounted on a 15 x 15 x 0.6 mm ceramic substrate.

2 Electrical characteristics^(a)

JANS and ESCC version of the products are assembled and tested in compliance with the agency specification it is qualified in. The electrical characteristics of each version are provided in dedicated tables.

T_{case} = 25 °C unless otherwise specified.

2.1 JANS electrical characteristics

Table 4. JANS electrical characteristics

Symbol	Parameter	Test conditions	Min.	Typ.	Max.	Unit
I _{CBO}	Collector cut-off current (I _E = 0)	V _{CB} = 60 V		-	10	μA
		V _{CB} = 50 V			10	nA
		V _{CB} = 50 V, T _{amb} = 150 °C			10	μA
I _{CES}	Collector cut-off current (I _E = 0)	V _{CE} = 50 V		-	50	nA
I _{EBO}	Emitter cut-off current (I _C = 0)	V _{EB} = 5 V		-	10	μA
		V _{EB} = 4 V			50	nA
V _{(BR)CEO} ⁽¹⁾	Collector-emitter breakdown voltage (I _B = 0)	I _C = 10 mA	60	-		V
V _{CE(sat)} ⁽¹⁾	Collector-emitter saturation voltage	I _C = 150 mA, I _B = 15 mA		-	0.4	V
		I _C = 500 mA, I _B = 50 mA			1.6	V
V _{BE(sat)} ⁽¹⁾	Base-emitter saturation voltage	I _C = 150 mA, I _B = 15 mA	0.6		1.3	V
		I _C = 500 mA, I _B = 50 mA			2.6	V
h _{FE} ⁽¹⁾	DC current gain	I _C = 0.1 mA, V _{CE} = 10 V	75	-		
		I _C = 1 mA, V _{CE} = 10 V	100		450	
		I _C = 10 mA, V _{CE} = 10 V	100			
		I _C = 150 mA, V _{CE} = 10 V	100		300	
		I _C = 500 mA, V _{CE} = 10 V	50			
		I _C = 10 mA, V _{CE} = 10 V T _{amb} = -55 °C	50			
h _{fe}	Small signal current gain	V _{CE} = 20 V I _C = 20 mA f = 100 MHz	2	-		
		V _{CE} = 10 V, I _C = 1 mA f = 1 kHz	100			

a. For PNP type, voltage and current values are negative.

Table 4. JANS electrical characteristics (continued)

Symbol	Parameter	Test conditions	Min.	Typ.	Max.	Unit
C_{obo}	Output capacitance ($I_E = 0$)	$V_{CB} = 10\text{ V}$ $100\text{ kHz} \leq f \leq 1\text{ MHz}$		-	8	pF
C_{ibo}	Output capacitance ($I_E = 0$)	$V_{EB} = 2\text{ V}$ $100\text{ kHz} \leq f \leq 1\text{ MHz}$		-	30	pF
t_{on}	Turn-on time	$V_{CC} = 30\text{ V}$, $I_C = 150\text{ mA}$ $I_{B1} = 15\text{ mA}$		-	45	ns
t_{off}	Turn-off time	$V_{CC} = 30\text{ V}$, $I_C = 150\text{ mA}$ $I_{B1} = -I_{B2} = 15\text{ mA}$		-	300	ns

1. Pulsed duration = 300 μs , duty cycle $\leq 2\%$

2.2 ESCC electrical characteristics

Table 5. ESCC electrical characteristics

Symbol	Parameter	Test conditions	Min.	Typ.	Max.	Unit
I_{CBO}	Collector cut-off current ($I_E = 0$)	$V_{CB} = 50\text{ V}$, $V_{CB} = 50\text{ V}$, $T_{amb} = 150\text{ }^\circ\text{C}$		-	10 10	nA μA
$V_{(BR)CBO}$	Collector-base breakdown voltage ($I_E = 0$)	$I_C = 10\text{ }\mu\text{A}$	60	-		V
$V_{(BR)CEO}^{(1)}$	Collector-emitter breakdown voltage ($I_B = 0$)	$I_C = 10\text{ mA}$	60	-		V
$V_{(BR)EBO}$	Emitter-base breakdown voltage ($I_C = 0$)	$I_E = 10\text{ }\mu\text{A}$	5	-		V
$V_{CE(sat)}^{(1)}$	Collector-emitter saturation voltage	$I_C = 150\text{ mA}$, $I_B = 15\text{ mA}$		-	0.4	V
$V_{BE(sat)}^{(1)}$	Base-emitter saturation voltage	$I_C = 150\text{ mA}$, $I_B = 15\text{ mA}$		0.87	1.3	V
$h_{FE}^{(1)}$	DC current gain	$I_C = 0.1\text{ mA}$, $V_{CE} = 10\text{ V}$	75	-		
		$I_C = 10\text{ mA}$, $V_{CE} = 10\text{ V}$	100			
		$I_C = 150\text{ mA}$, $V_{CE} = 10\text{ V}$	100		300	
		$I_C = 500\text{ mA}$, $V_{CE} = 10\text{ V}$	50			
h_{fe}	Small signal current gain	$V_{CE} = 20\text{ V}$, $I_C = 20\text{ mA}$ $f = 100\text{ MHz}$	2	-		
C_{obo}	Output capacitance ($I_E = 0$)	$V_{CB} = 10\text{ V}$ $100\text{ kHz} \leq f \leq 1\text{ MHz}$		-	8	pF

Table 5. ESCC electrical characteristics (continued)

Symbol	Parameter	Test conditions	Min.	Typ.	Max.	Unit
t_{on}	Turn-on time	$V_{CC} = 30\text{ V}$, $I_C = 150\text{ mA}$ $I_{B1} = 15\text{ mA}$		-	45	ns
t_{off}	Turn-off time	$V_{CC} = 30\text{ V}$, $I_C = 150\text{ mA}$ $I_{B1} = -I_{B2} = 15\text{ mA}$		-	300	ns

1. Pulsed duration = 300 μs , duty cycle $\leq 2\%$

2.3 Electrical characteristics (curves)

Figure 2. Safe operating area for TO-18

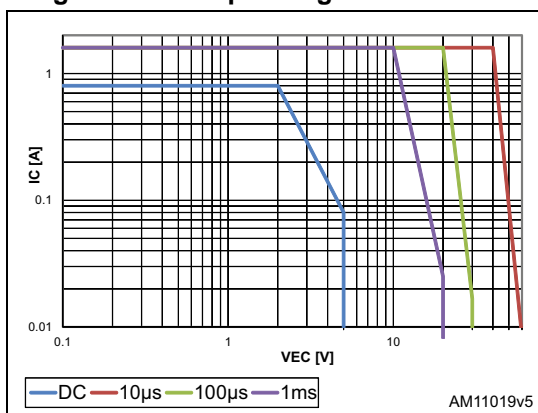

Figure 3. Safe operating area for LCC-3

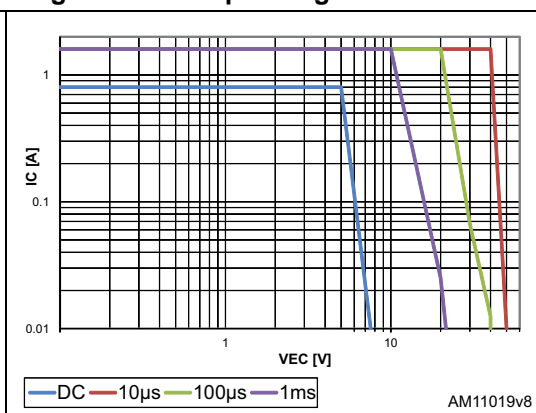

Figure 4. DC current gain ($V_{CE} = 1\text{ V}$)

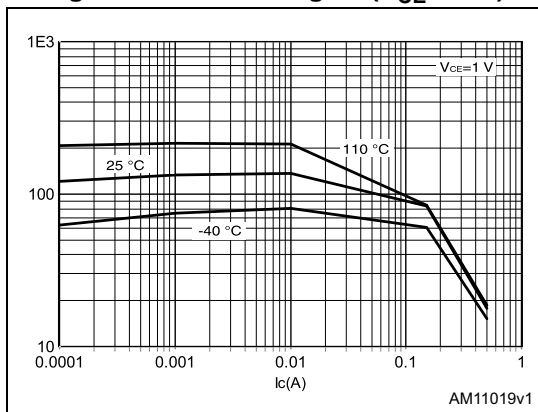

Figure 5. DC current gain ($V_{CE} = 10\text{ V}$)

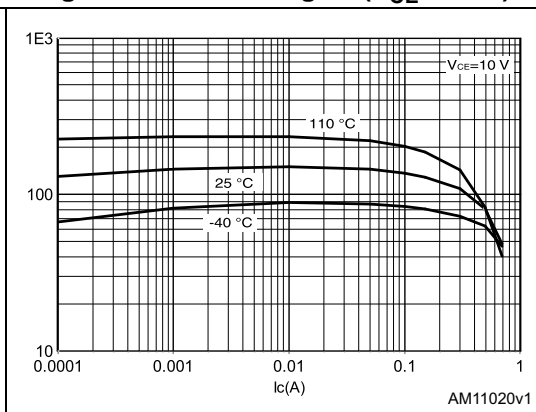

Figure 6. Collector emitter saturation voltage

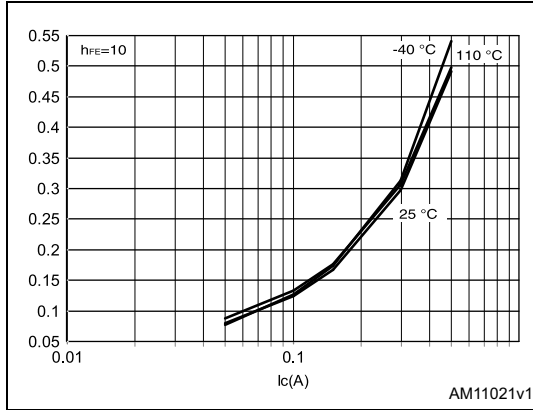
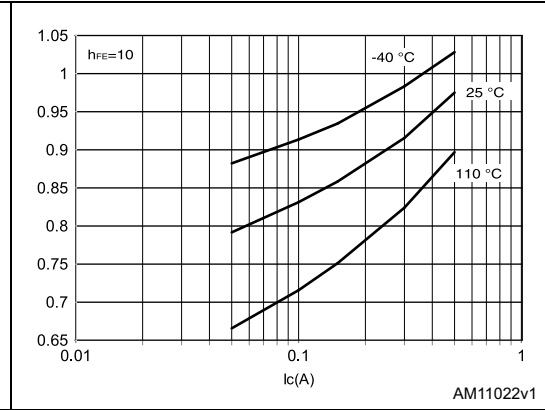

Figure 7. Base emitter saturation voltage (h_{FE} = 10)



2.4 Test circuits

Figure 8. JANS saturated turn-on switching time test circuit

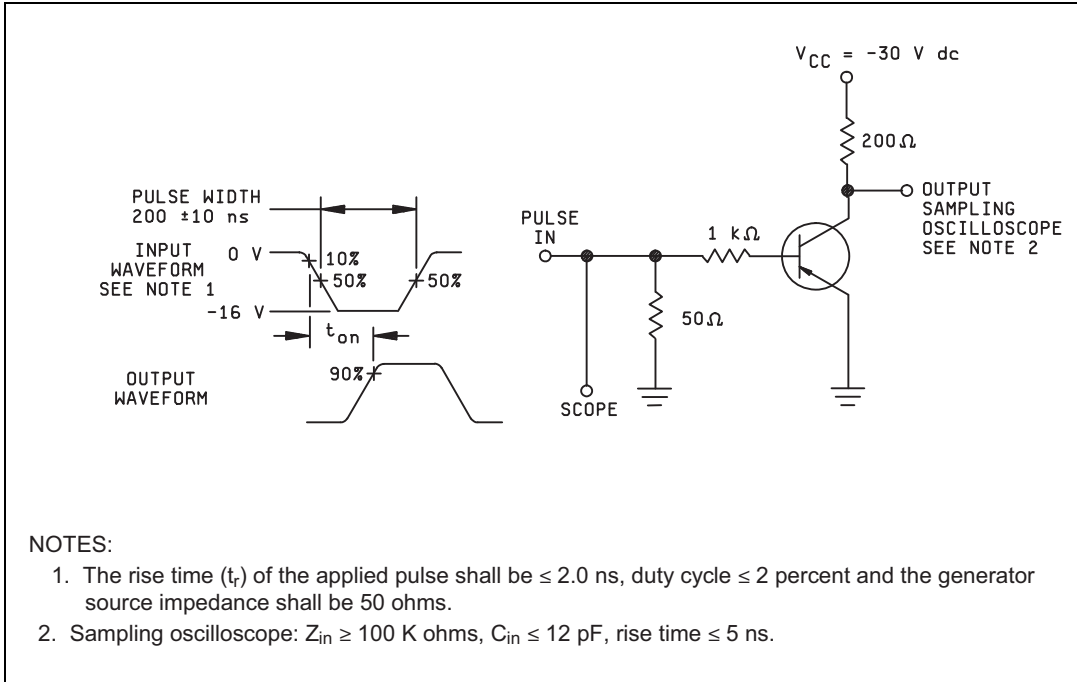

Figure 9. JANS saturated turn-off switching time test circuit

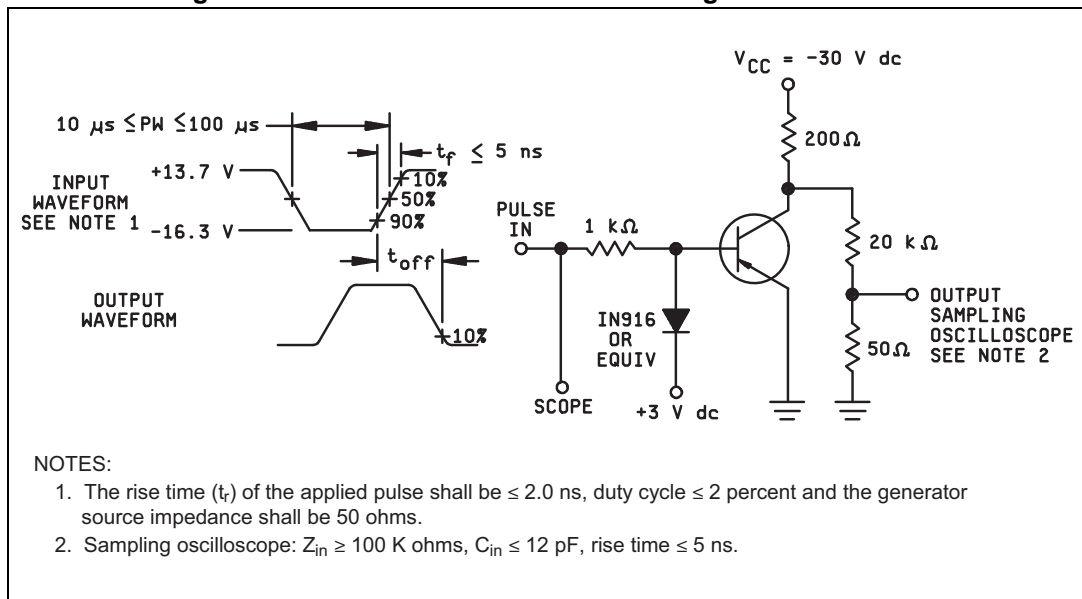
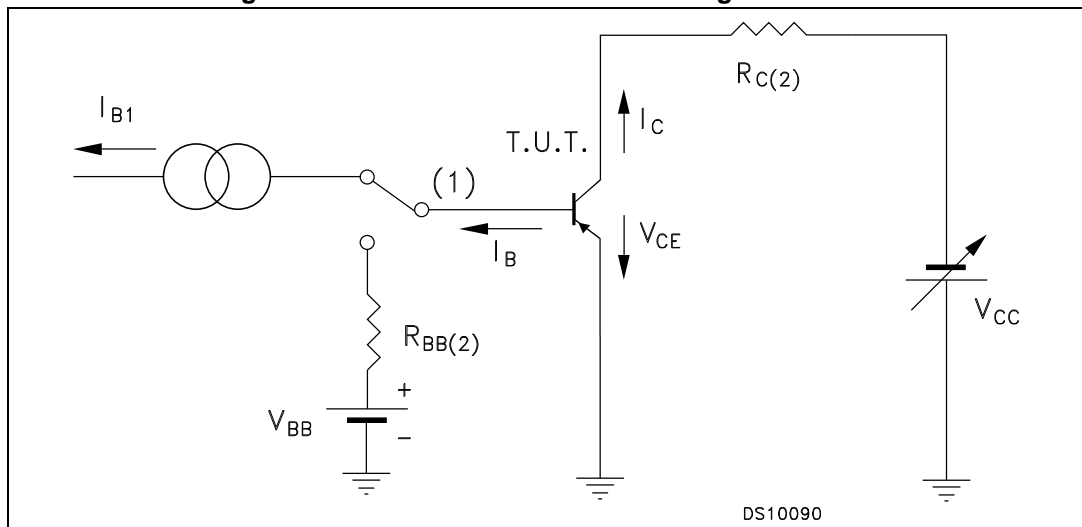

Figure 10. ESCC resistive load switching test circuit



1. Fast electronic switch
2. Non-inductive resistor

3 Radiation hardness assurance

The products guaranteed in radiation within the JANS system fully comply with the MIL-PRF-19500/291 specification.

The products guaranteed in radiation within the ESCC system fully comply with the ESCC 5202/001 and ESCC 22900 specifications.

JANS radiation assurance

ST JANS parts guaranteed at 100 krad (Si), tested, in full compliancy with the MIL-PRF-19500 specification, specifically the Group D, subgroup 2 inspection, between 50 and 300 rad/s. On top of the standard JANSR high dose rate by wafer lot guarantee, ST 2N2907AHR series include an additional wafer by wafer 100 krad Low dose rate guarantee at 0.1 rad/s, identical to the ESCC 100 krad guarantee. It is supported with the same Radiation Verification Test report provided with each shipment. A brief summary of the standard High Dose Rate by wafer lot JANSR guarantee is provided below:

- All test are performed in accordance to MIL-PRF-19500 and test method 1019 of MIL-STD-750 for total Ionizing dose.

The table below provides for each monitored parameters of the test conditions and the acceptance criteria

Table 6. MIL-PRF-19500 (test method 1019) post radiation electrical characteristics

Symbol	Parameter	Test conditions	Value		Unit
			Min.	Max.	
I_{CBO}	Collector to base cutoff current	$V_{CB} = 60$		20	μA
		$V_{CB} = 50 V$		20	nA
I_{EBO}	Emitter to base cutoff current	$V_{EB} = 5 V$		20	μA
		$V_{EB} = 4 V$		100	nA
$V_{(BR)CEO}$	Breakdown voltage, collector to emitter	$I_C = 10 mA$	60		V
I_{CES}	Collector to emitter cutoff current	$V_{CE} = 50 V$		100	nA
h_{FE}	Forward-current transfer ratio	$V_{CE} = 10 V; I_C = 0.1 mA$	[37.5] ⁽¹⁾		
		$V_{CE} = 10 V; I_C = 1.0 mA$	[50] ⁽¹⁾	400	
		$V_{CE} = 10 V; I_C = 10 mA$	[50] ⁽¹⁾		
		$V_{CE} = 10 V; I_C = 150 mA$	[50] ⁽¹⁾	300	
		$V_{CE} = 10 V; I_C = 500 mA$	[25] ⁽¹⁾		
$V_{CE(sat)}$	Collector-emitter saturation voltage	$I_C = 150 mA; I_B = 15 mA$		0.46	V
		$I_C = 500 mA; I_B = 50 mA$		1.84	
$V_{BE(sat)}$	Base-emitter saturation voltage	$I_C = 150 mA; I_B = 15 mA$	0.6	1.5	V
		$I_C = 500 mA; I_B = 50 mA$		3	

1. See method 1019 of MIL-STD-750 for how to determine $[h_{FE}]$ by first calculating the delta ($1/h_{FE}$) from the pre- and Post-radiation h_{FE} . Notice the $[h_{FE}]$ is not the same as h_{FE} and cannot be measured directly. The $[h_{FE}]$ value can never exceed the pre-radiation minimum h_{FE} that it is based upon.

ESCC radiation assurance

Each product lot is tested according to the ESCC basic specification 22900, with a minimum of 11 samples per diffusion lot and 5 samples per wafer, one sample being kept as unirradiated sample, all of them being fully compliant with the applicable ESCC generic and/or detailed specification.

ST goes beyond the ESCC specification by performing the following procedure:

- Test of 11 pieces by wafer, 5 biased at least 80% of $V_{(BR)CEO}$, 5 unbiased and 1 kept for reference
- Irradiation at 0.1 rad (Si)/s
- Acceptance criteria of each individual wafer if as 100 krad guaranteed if all 10 samples comply with the post radiation electrical characteristics provided in [Table 8](#).

Delivery together with the parts of the radiation verification test (RVT) report of the particular wafer used to manufacture the products. This RVT includes the value of each parameter at 30, 50, 70 and 100 krad (Si) and after 24 hour annealing at room temperature and after an additional 168 hour annealing at 100°C.

Table 7. Radiation summary

Radiation test	100 krad ESCC
Wafer test	each
Part tested	5 biased + 5 unbiased
Dose rate	0.1 rad/s
Acceptance	MIL-STD-750 method 1019
Displacement damage	Optional
Agency part number (ex)	5202/001/04R ⁽¹⁾
ST part number (ex)	SOC2N2907ARHRG
Documents	CoC + RVT

1. Example of the 2N2907A in LCC-3 Gold finish.



Table 8. ESCC 5202/001R post radiation electrical characteristics

Symbol	Parameter	Test conditions	Min.	Typ.	Max.	Unit
I_{CBO}	Collector cut-off current ($I_E = 0$)	$V_{CB} = 50 \text{ V}$		-	10	nA
I_{EBO}	Emitter cut-off current ($I_C = 0$)	$V_{EB} = 3 \text{ V}$		-	10	nA
$V_{(BR)CBO}$	Collector-base breakdown voltage ($I_E = 0$)	$I_C = 10 \mu\text{A}$	60	-		V
$V_{(BR)CEO}^{(1)}$	Collector-emitter breakdown voltage ($I_B = 0$)	$I_C = 10 \text{ mA}$	60	-		V V
$V_{(BR)EBO}$	Emitter-base breakdown voltage ($I_C = 0$)	$I_E = 10 \mu\text{A}$	5	-		V
$V_{CE(sat)}^{(1)}$	Collector-emitter saturation voltage	$I_C = 150 \text{ mA}$ $I_B = 15 \text{ mA}$		-	0.4	V
$V_{BE(sat)}^{(1)}$	Base-emitter saturation voltage	$I_C = 150 \text{ mA}$ $I_B = 15 \text{ mA}$			1.3	V
$[h_{FE}]^{(1)}$	Post irradiation gain calculation ⁽²⁾	$I_C = 0.1 \text{ mA}$ $V_{CE} = 10 \text{ V}$ $I_C = 10 \text{ mA}$ $V_{CE} = 10 \text{ V}$ $I_C = 150 \text{ mA}$ $V_{CE} = 10 \text{ V}$ $I_C = 500 \text{ mA}$ $V_{CE} = 10 \text{ V}$	[37.5] [50] [100] [25]	-	300	

1. Pulsed duration = 300 μs , duty cycle $\leq 2\%$

2. The post-irradiation gain calculation of $[h_{FE}]$, made using h_{FE} measurements from prior to and on completion of irradiation testing and after each annealing step if any, shall be as specified in MILSTD-750 method 1019.

4 Package mechanical data

In order to meet environmental requirements, ST offers these devices in different grades of ECOPACK[®] packages, depending on their level of environmental compliance. ECOPACK[®] specifications, grade definitions and product status are available at: www.st.com. ECOPACK[®] is an ST trademark.

Table 9. Product mass summary

Package	Mass (g)
UB	0.06
LCC-3	0.06
TO-18	0.40

4.1 UB

Figure 11. UB drawings

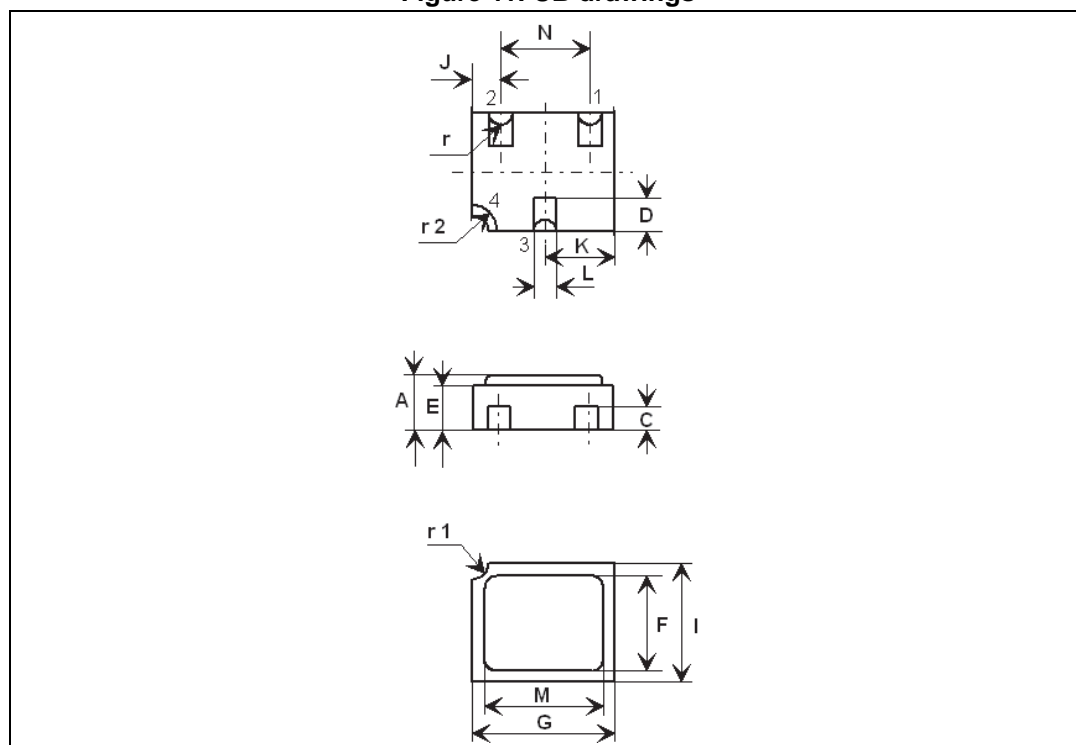

Table 10. UB mechanical data

Dim.	mm.		
	Min.	Typ.	Max.
A	1.16		1.42
C	0.46	0.51	0.56
D	0.56	0.76	0.96
E	0.92	1.02	1.12
F	1.95	2.03	2.11
G	2.92	3.05	3.18
I	2.41	2.54	2.67
J	0.42	0.57	0.72
K	1.37	1.52	1.67
L	0.41	0.51	0.61
M	2.46	2.54	2.62
N	1.81	1.91	2.01
r		0.20	
r1		0.30	
r2		0.56	

4.2 LCC-3

Figure 12. LCC-3 drawings

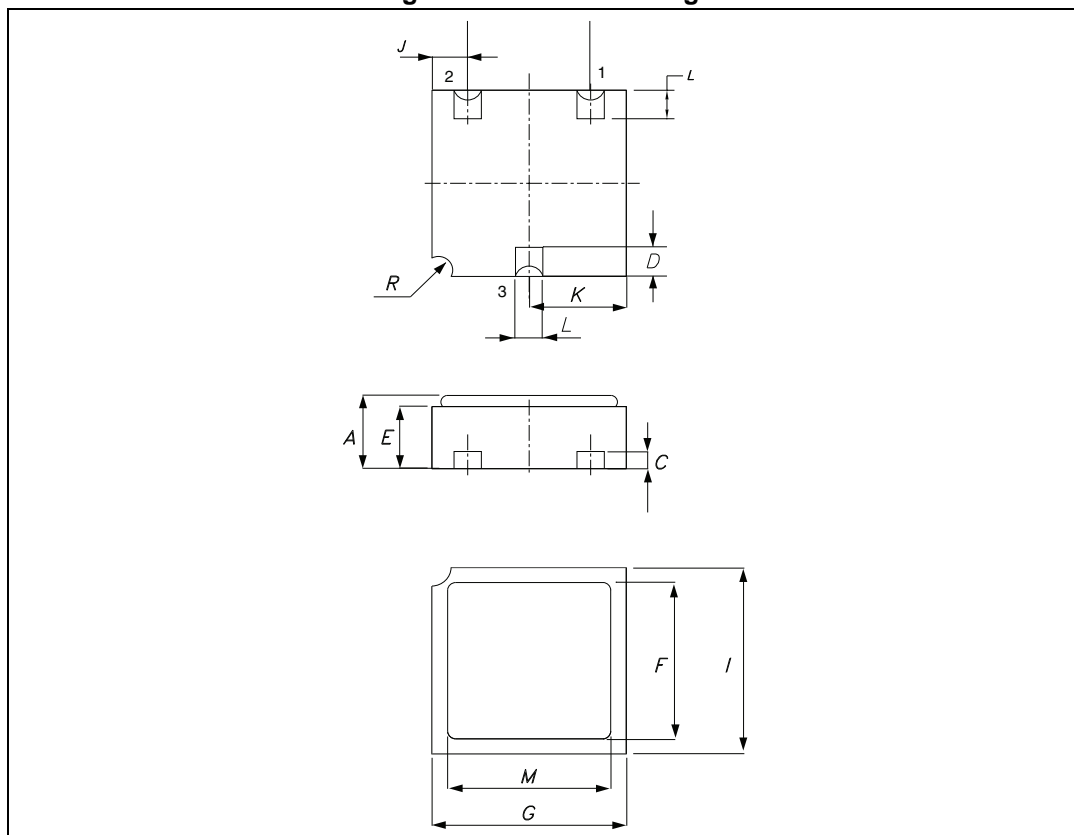

Table 11. LCC-3 mechanical data

Dim.	mm.		
	Min.	Typ.	Max.
A	1.16		1.42
C	0.45	0.50	0.56
D	0.60	0.76	0.91
E	0.91	1.01	1.12
F	1.95	2.03	2.11
G	2.92	3.05	3.17
I	2.41	2.54	2.66
J	0.42	0.57	0.72
K	1.37	1.52	1.67
L	0.40	0.50	0.60
M	2.46	2.54	2.62
N	1.80	1.90	2.00
R		0.30	

4.3 TO-18

Figure 13. TO-18 drawings

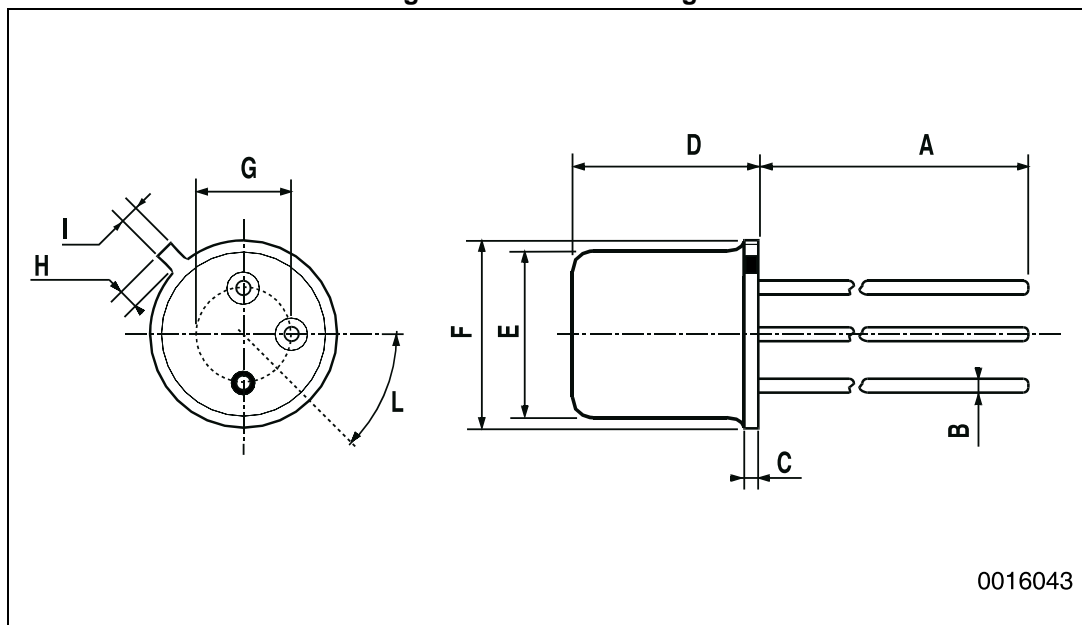

Table 12. TO-18 mechanical data

Dim.	mm.		
	Min.	Typ.	Max.
A		12.7	
B			0.49
D			5.3
E			4.9
F			5.8
G	2.54		
H			1.2
I			1.16
L	45°		



5 Order codes

Table 13. Ordering information

CPN	Agency specification	EPPL	Quality level	Radiation level ⁽¹⁾	Package	Lead finish	Marking ⁽²⁾	Packing
J2N2907AUB1	-	-	Engineering Model JANS	-	UB	Gold	J2907AUB1	Waffle Pack
2N2907AUB1	-	-	Engineering Model ESCC	-	UB	Gold	2N2907AUB1	Waffle Pack
SOC2907A1	-	-	Engineering Model ESCC	-	LCC-3	Gold	SOC2907A1	Waffle Pack
2N2907A1	-	-	Engineering Model ESCC	-	TO-18	Solder Dip	2N2907A1	Strip Pack
JANSR2N2907AUBG	MIL-PRF-19500/291	-	JANSR	100krad - high and low dose rate	UB	Gold	JSR2907	Waffle Pack
JANSR2N2907AUBT	MIL-PRF-19500/291	-	JANSR	100krad - high and low dose rate	UB	Solder Dip	JSR2907	Waffle Pack
JANS2N2907AUBG	MIL-PRF-19500/291	-	JANS	-	UB	Gold	JS2907	Waffle Pack
JANS2N2907AUBT	MIL-PRF-19500/291	-	JANS	-	UB	Solder Dip	JS2907	Waffle Pack
2N2907ARUBG	5202/001/06R	Target	ESCC Flight	100krad - low dose rate	UB	Gold	520200106R	Waffle Pack
2N2907ARUBT	5202/001/07R	Target	ESCC Flight	100krad - low dose rate	UB	Solder Dip	520200107R	Waffle Pack
2N2907AUBG	5202/001/06	Target	ESCC Flight	-	UB	Gold	520200106	Waffle Pack
2N2907AUBT	5202/001/07	Target	ESCC Flight	-	UB	Solder Dip	520200107	Waffle Pack
SOC2907ARHRG	5202/001/04R	Yes	ESCC Flight	100krad - low dose rate	LCC-3	Gold	520200104R	Waffle Pack
SOC2907ARHRT	5202/001/05R	Yes	ESCC Flight	100krad - low dose rate	LCC-3	Solder Dip	520200105R	Waffle Pack
SOC2907AHRG	5202/001/04	Yes	ESCC Flight	-	LCC-3	Gold	520200104	Waffle Pack

DocID15382 Rev 8

17/21

2N2907AHR

Order codes



Table 13. Ordering information

CPN	Agency specification	EPPL	Quality level	Radiation level ⁽¹⁾	Package	Lead finish	Marking ⁽²⁾	Packing
SOC2907AHRT	5202/001/05	Yes	ESCC Flight	-	LCC-3	Solder Dip	520200105	Waffle Pack
2N2907ARHRG	5202/001/01R	-	ESCC Flight	100krad - low dose rate	TO-18	Gold	520200101R	Strip Pack
2N2907ARHRT	5202/001/02R	-	ESCC Flight	100krad - low dose rate	TO-18	Solder Dip	520200102R	Strip Pack
2N2907AHRG	5202/001/01	-	ESCC Flight	-	TO-18	Gold	520200101	Strip Pack
2N2907AHRT	5202/001/02	-	ESCC Flight	-	TO-18	Solder Dip	520200102	Strip Pack

1. High dose rate as per MIL-PRF-19500 specification group D, subgroup 2 inspection. Low dose rate as per ESCC specification 22900.
2. Specific marking only. The full marking includes in addition: For the Engineering Models: ST logo, date code; country of origin (FR). For ESCC flight parts: ST logo, date code, country of origin (FR), ESA logo, serial number of the part within the assembly lot. For JANS flight parts: ST logo, date code, country of origin (FR), manufacturer code (CSTM), serial number of the part within the assembly lot.

Contact ST sales office for information about the specific conditions for:

- Products in die form
- Other JANS quality levels
- Tape and reel packing

6 Shipping details

6.1 Date code

Date code xyywwz is structured as below table:

Table 14. Date code

	x	yy	ww	z
EM (ESCC & JANS)	3	last two digits of the year	week digits	lot index in the week
ESCC FLIGHT	-			
JANS FLIGHT (diffused in Singapore)	W			

6.2 Documentation

Table 15. Documentation provided for each type of product

Quality level	Radiation level	Documentation
Engineering model	-	-
JANS Flight	-	Certificate of conformance
JANS Flight	100 krad	Certificate of conformance 50 rad/s radiation verification test report
ESCC Flight	-	Certificate of conformance
ESCC Flight	100 krad	Certificate of conformance 0.1 rad/s radiation verification test report

7 Revision history

Table 16. Document revision history

Date	Revision	Changes
09-Feb-2009	1	Initial release
05-Jan-2010	2	Modified Table 1: Device summary
30-Nov-2011	3	Minor text changes in the document title and description on the coverpage
14-May-2012	4	New package inserted (UB). Updated: – Table 1: Device summary , Table 2: Absolute maximum ratings and Table 3: Thermal data . – Section 2: Electrical characteristics and Section 4: Package mechanical data . Added: – Section 5: Shipping details and Section 6: Shipping details .
03-Jun-2013	5	Added: – New section Radiation hardness assurance – Corrected the revision number and dates of revision 3
18-Sep-2013	6	Updated Table 1: Device summary and Table 13: Ordering information
05-May-2014	7	Updated Table 1: Device summary , Table 13: Ordering information and Section 3: Radiation hardness assurance . Added Figure 2: Safe operating area for TO-18 and Figure 3: Safe operating area for LCC-3
29-May-2014	8	Added note 1 in Table 13: Ordering information .

Please Read Carefully:

Information in this document is provided solely in connection with ST products. STMicroelectronics NV and its subsidiaries ("ST") reserve the right to make changes, corrections, modifications or improvements, to this document, and the products and services described herein at any time, without notice.

All ST products are sold pursuant to ST's terms and conditions of sale.

Purchasers are solely responsible for the choice, selection and use of the ST products and services described herein, and ST assumes no liability whatsoever relating to the choice, selection or use of the ST products and services described herein.

No license, express or implied, by estoppel or otherwise, to any intellectual property rights is granted under this document. If any part of this document refers to any third party products or services it shall not be deemed a license grant by ST for the use of such third party products or services, or any intellectual property contained therein or considered as a warranty covering the use in any manner whatsoever of such third party products or services or any intellectual property contained therein.

UNLESS OTHERWISE SET FORTH IN ST'S TERMS AND CONDITIONS OF SALE ST DISCLAIMS ANY EXPRESS OR IMPLIED WARRANTY WITH RESPECT TO THE USE AND/OR SALE OF ST PRODUCTS INCLUDING WITHOUT LIMITATION IMPLIED WARRANTIES OF MERCHANTABILITY, FITNESS FOR A PARTICULAR PURPOSE (AND THEIR EQUIVALENTS UNDER THE LAWS OF ANY JURISDICTION), OR INFRINGEMENT OF ANY PATENT, COPYRIGHT OR OTHER INTELLECTUAL PROPERTY RIGHT.

ST PRODUCTS ARE NOT DESIGNED OR AUTHORIZED FOR USE IN: (A) SAFETY CRITICAL APPLICATIONS SUCH AS LIFE SUPPORTING, ACTIVE IMPLANTED DEVICES OR SYSTEMS WITH PRODUCT FUNCTIONAL SAFETY REQUIREMENTS; (B) AERONAUTIC APPLICATIONS; (C) AUTOMOTIVE APPLICATIONS OR ENVIRONMENTS, AND/OR (D) AEROSPACE APPLICATIONS OR ENVIRONMENTS. WHERE ST PRODUCTS ARE NOT DESIGNED FOR SUCH USE, THE PURCHASER SHALL USE PRODUCTS AT PURCHASER'S SOLE RISK, EVEN IF ST HAS BEEN INFORMED IN WRITING OF SUCH USAGE, UNLESS A PRODUCT IS EXPRESSLY DESIGNATED BY ST AS BEING INTENDED FOR "AUTOMOTIVE, AUTOMOTIVE SAFETY OR MEDICAL" INDUSTRY DOMAINS ACCORDING TO ST PRODUCT DESIGN SPECIFICATIONS. PRODUCTS FORMALLY ESCC, QML OR JAN QUALIFIED ARE DEEMED SUITABLE FOR USE IN AEROSPACE BY THE CORRESPONDING GOVERNMENTAL AGENCY.

Resale of ST products with provisions different from the statements and/or technical features set forth in this document shall immediately void any warranty granted by ST for the ST product or service described herein and shall not create or extend in any manner whatsoever, any liability of ST.

ST and the ST logo are trademarks or registered trademarks of ST in various countries.

Information in this document supersedes and replaces all information previously supplied.

The ST logo is a registered trademark of STMicroelectronics. All other names are the property of their respective owners.

© 2014 STMicroelectronics - All rights reserved

STMicroelectronics group of companies

Australia - Belgium - Brazil - Canada - China - Czech Republic - Finland - France - Germany - Hong Kong - India - Israel - Italy - Japan - Malaysia - Malta - Morocco - Philippines - Singapore - Spain - Sweden - Switzerland - United Kingdom - United States of America

www.st.com

